

# Owners Manual

Öhlins road & track front fork FG 43



Including:

Safety

Adjusters

Setting up  
your fork

Changing  
springs

Oil level  
adjustment

Technical  
information

Inspection &  
maintenance

Service Tools



## Safety signals

Important information concerning safety is distinguished in this manual by the following notations:



*The Safety alert symbol means:  
Caution! Your safety is involved.*

### **WARNING!**

*Failure to follow warning instructions could result in **severe or fatal injury** to anyone working with, inspecting or using the suspension, or to bystanders.*

### **CAUTION!**

*Caution indicates that special precautions must be taken to avoid damage to the suspension.*

### **NOTE!**

*This indicates information that is of importance with regard to procedures.*

## Introduction

All of Öhlins advanced suspension products are adapted to the brand and model. This means that length, travel spring action and damping characteristics, are tested individually just for the motorcycle that you have decided to fit with Öhlins suspension.

## Before installation

Öhlins Racing AB can not be held responsible for any damage whatsoever to suspension or vehicle, or injury to persons, if the instructions for fitting and maintenance are not followed exactly. Similarly, the warranty will become null and void if the instructions are not adhered to.

## Contents

Introduction .....	3
Adjuster .....	4
Setting up your fork .....	5
Setting the pre-load .....	6
Changing springs .....	7
Oil level adjustment .....	8
Technical information .....	9
Inspection & maintenance .....	10
Service tools .....	11

### **WARNING!**

*1. Installing a suspension, that is not approved by the vehicle manufacturer, may affect the stability of your vehicle. Öhlins Racing AB cannot be held responsible for any personal injury or damage whatsoever that may occur after fitting the suspension. Contact an Öhlins dealer or other qualified person for advice.*

*2. Please study and make certain that you fully understand all the mounting instructions and the owner's manuals before handling this suspension kit. If you have any questions regarding proper installation procedures, contact an Öhlins dealer or other qualified person.*

*3. The vehicle service manual must be referred to when installing the Öhlins suspension.*

### **NOTE**

*Öhlins products are subject to continual improvement and development. Consequently, although these instructions include the most up-to-date information available at the time of printing, there may be minor differences between your suspension and this manual. Please consult your Öhlins dealer if you have any questions with regard to the contents of the manual.*

### **NOTE!**

*During storage and transportation, especially at high ambient temperature, the oil and grease used for assembling may run out inside the packing and damage the expanded polystyrene packing material. This is not unusual and is in no way detrimental to the suspension.*

© Öhlins Racing AB.

All rights reserved.

Any reprinting or unauthorized use without the written permission of Öhlins Racing AB is prohibited.

Printed in Sweden.

## Öhlins front fork FG 43

The Öhlins front forks use a cartridge system for damping. This gives a damping force which depends on the speed of the piston in the cartridge system.

The combination of spring and air volume (oil level) offers a possibility to adjust the characteristics of the fork to suit different tracks and riders.

For example a soft spring in combination with a small air volume (high oil level) gives progressive action of the front forks.

For better understanding, please refer to our oil level chart, see page 8.

A telescopic front fork depends on smooth friction free action.

Make sure your front forks are serviced regularly and don't use strong solvents such as brake cleaner to clean the front forks. This will dry out the seals and steel tubes and cause friction.

Regularly put a little Öhlins red grease (146-01) regularly on the steel tube and work it in by pushing the forks up and down.

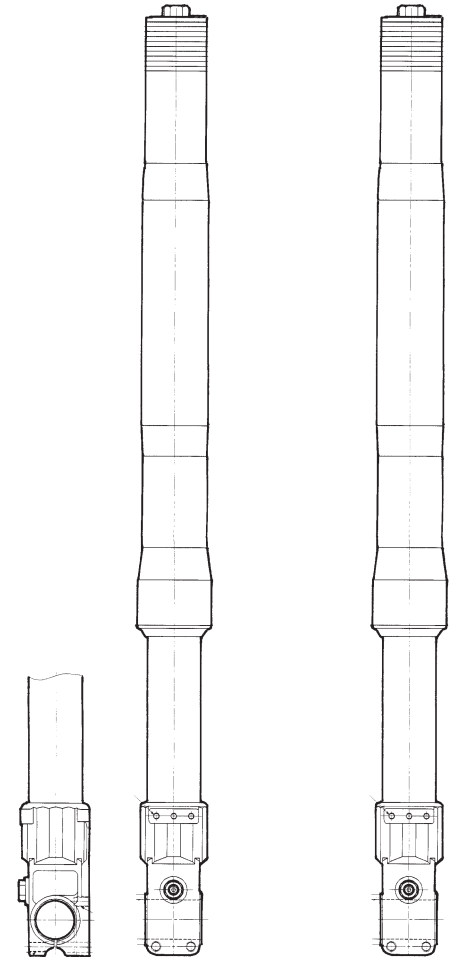

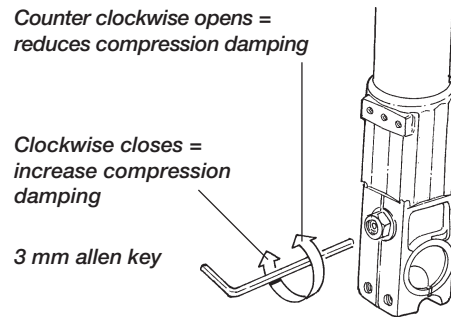
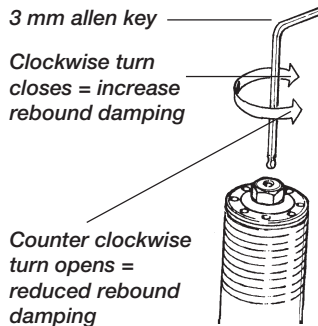
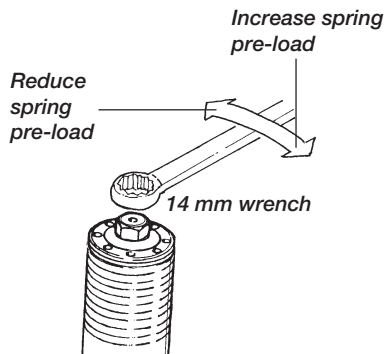

## Adjusters

Your øhins front fork ø 43 is provided with the following adjusters

- Spring pre-load
- Rebound damping adjuster
- Compression damping adjuster

### Spring pre-load adjustment

Use 14 mm wrench to turn the upper adjustment screw.

### NOTE!

*On some models adjustments are made with 12 mm wrench. These models has two larger nuts below the adjustment screw and the top nut assy*

Maximum adjustment range is 18 mm. One turn of the adjustment screw will cause 1 mm change in spring preload. Adjust so the front forks are lowered 25-30 mm from the top, unloaded position.

### Rebound adjustment

Adjust the rebound rate on the adjustment screws positioned at the top centre of the front forks. Use a 3 mm allen key with a spherical head (use tool 794-01).

Adjustment range from closed valve (clockwise) to maximum open valve (counter-clockwise) is 20 “clicks”. See mounting instruction for recommended adjustment “clicks”, from closed position.

### Compression adjustment

Adjust the compression rate on the lower part of the front forks (compression valve). Use a 3 mm allen key with spherical head (use tool 794-01).

Adjustment range from closed valve (clockwise) to maximum open valve (counter-clockwise) is 20 “clicks”.

See mounting instruction for recommended adjustment “clicks”, from closed position.

### 3. Static sag B-A

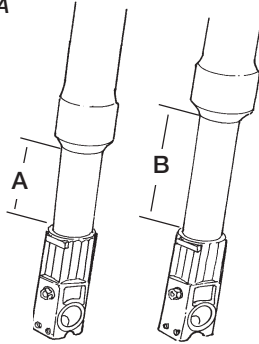

## Setting up your fork

Here are some basic guidelines for setting up your Öhlins front forks. However, you must remember that the front forks are just one part of your motorcycle and to get it to work properly, the whole motorcycle has to be set up in conformance with its manual.

### 1

Put your bike on a front stand so you can fit the front forks.

Maximum torque on the bottom triple clamp and steering damper bracket (if it is located on the diameter of the outer tube) is 15-18 Nm.

Dismantle the front wheel and brakes.

### 2

Unscrew the adjustment housing on top of the fork (use tool 797-04) on both upper tubes and slide the fork up and down gently to make sure everything works correctly.

### 3

Assemble the adjustment housing again and set your initial preload of the spring by using a 12 mm or a 17 mm wrench until you get a “static sag” of 25-30 mm.

Each turn gives 1 mm in preload. Maximum preload is 15 mm.

### 4

The best way to check the “static sag” is to put the bike on the ground in running condition.

Measure the distance between the bottom of the outer tube to the fork bottom. Then lift the front end of the bike, so the fork is fully extended. Measure again. The difference between these two figures is the “static sag”.

### 5

The “clicks” are a “bleed function”, separate for rebound and compression damping. Rebound adjustment is made on the top centre of the fork and compression adjustment at the bottom part of the fork.

You start to count from fully closed (clockwise) and set it to the recommended “click” (use a 3 mm Allen key). For recommended start setting, please refer to the mounting instruction.

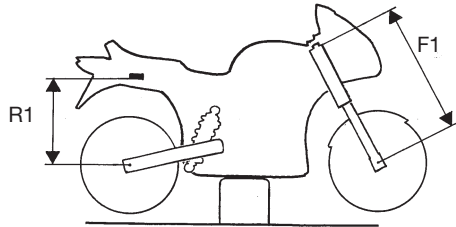

*Bike on a stand*

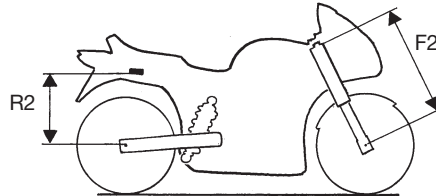

*Bike on the ground*

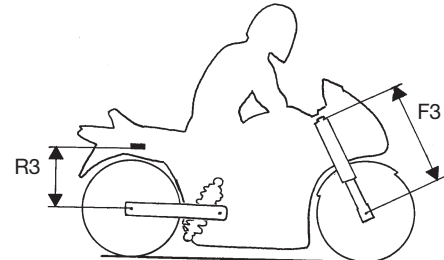

*Bike with rider on*

## Setting the spring pre-load

### 6

Pre-load on the spring/springs is very important, because it affects the height of the motorcycle and the fork angle. Consequently, handling characteristics can be changed, even negatively.

Proceed as follows (it will be much easier if done by two persons):

- 1 Place the motorcycle on a stand.
- 2 Lift up the rear end to a fully extended position.
- 3 Measure the distance, e.g. from the lower edge of the rear mud guard or from a point marked by a piece of tape, immediately above the rear wheel axle, to the wheel axle. (R1)

- 4 Make a similar measurement on the front axle, e.g. from the bottom of the upper fork crown to the front wheel axle. The fork must also be fully extended. (F1)
- 5 Allow the motorcycle (without rider) to apply load on the springs and repeat the measuring procedure. (R2, F2)
- 6 Then take the same measurements with the rider and equipment on the motorcycle. It is important that the rider has a correct riding posture, so that the weight is balanced on the front and rear wheel in the same way as when riding. (R3, F3)

### 7

The measurements may not differ from the following sizes:

#### Without rider:

Rear:	10-20 mm	(R1-R2)
Front:	15-30 mm	(F1-F2)

#### With rider:

Rear:	25-40 mm	(R1-R3)
Front:	35-50 mm	(F1-F3)

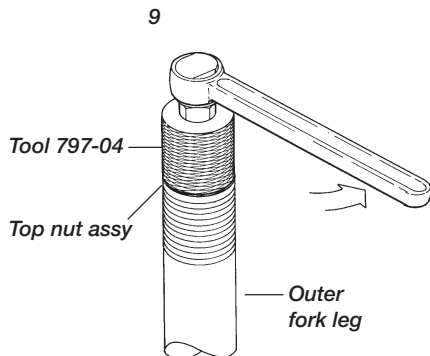

## Changing springs

**8**

Loosen the screws that hold the fork legs in the upper triple clamps.

**9**

Loosen the top nut assy (page 7) about two turns (use tool 797-04).

**10**

Remove the fork legs from the motorcycle.

**11**

Grip a fork leg in a vice. Use soft jaws.

**12**

Unload the spring completely by turning the adjustment screw anticlockwise. Use a 12 mm or a 14 mm wrench.

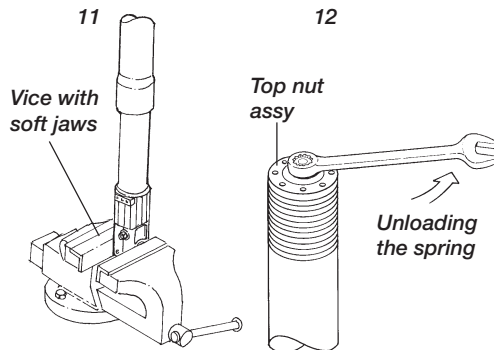

### CAUTION!

*Do not damage the O-ring and do not drop the flat key into the fork leg.  
Carefully remove the adjustment housing.*

**13**

Remove the adjustment driver, the pre-load tube and spring.

### CAUTION!

*The pre-load tube can be positioned above or below the spring, depending on type of front fork.  
Take note when disassembling!*

**14**

Pull out the piston rod as far as possible and turn the compression adjustment screw fully clockwise. This will keep the piston rod in top position, which will make the continued assembly easier.

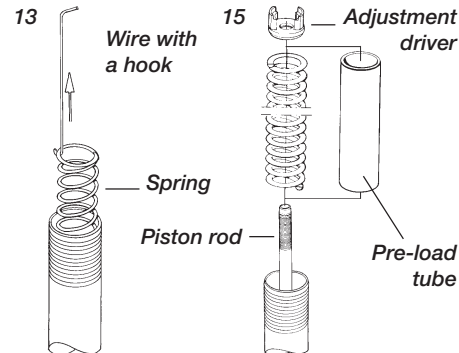

**15**

Install the new spring, the adjustment driver and the preload tube. Be careful to put all parts back in the same position as when the fork was reassembled.

**16**

Reinstall the top nut assy.

### CAUTION!

*Some models of top nut are equipped with a flat key, that must be guided into the slot of the top nut assy.*

**17**

Fasten the adjustment housing in the fork leg. Make sure that the fork leg is fully extended when tightening the adjustment housing.

**18**

Install the fork legs on the motorcycle and adjust the pre-load, compression and rebound according to the instructions at page 4.

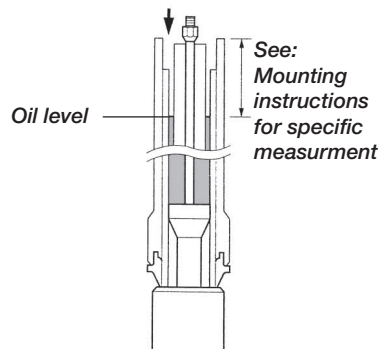

### Oil level adjustment

Compared to conventional type of front forks, the upside down front forks are very sensitive to variations in oil level. Therefore, adjust the oil level with special care.

A change in the fork oil level will not affect damping force in the early stage of fork travel, but will have a great effect in the later stage.

#### When the oil level is raised:

The air spring in the later half stage of travel is stronger, and thus the front forks harder.

#### When the oil level is lowered:

The air spring in the later half stage of travel is lessened, and thus the front forks are softer. The oil level works most effectively at the end of the fork travel. Air spring characteristics shown, refer to a general card description to facilitate understanding of the difference when the oil level is changed.

## Air spring characteristics

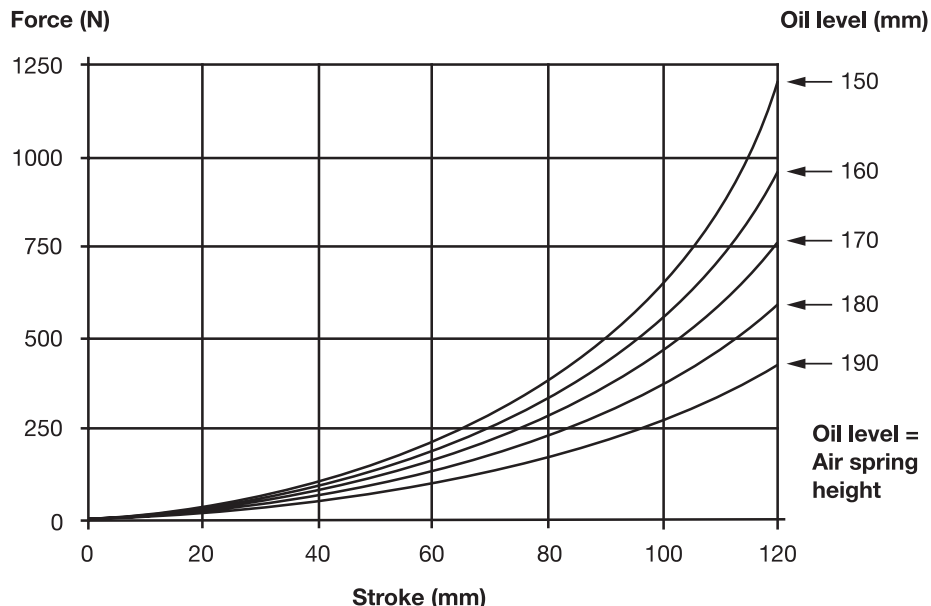

### NOTE!

Adjust the oil level in mm according to the figure with the fork fully compressed and with the spring and the pre-load tube removed. For the right recommended level, please see the mounting instruction.

### Front spring kit

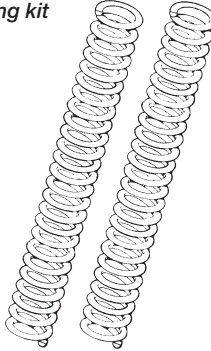

## Technical information

### Fork length:

See Mounting instructions.

### Stroke:

See Mounting instructions.

### Free spring length:

See mounting instructions.

### Rebound adjustment:

Basic setting 9-12 “clicks”.

Maximum open valve 20 “clicks”.

### Compression adjustment:

Basic setting 6-16 “clicks”.

Maximum open valve 20 “clicks”.

### Spring preload adjustment:

0-15 mm (0-15 turns).

### Spring rate

See Mounting instructions.

### Optional springs are available in following rates:

04744-80 8.0 N/mm

04744-85 8.5 N/mm

04744-90 9.0 N/mm

04744-95 9.5 N/mm

04744-10 10.0 N/mm

### Oil Level:

Please see Mounting instructions for the specific front fork

## CAUTION!

*Use only Öhlins high performance front fork fluid (1309-01).*

### Loctite glue:

542 on Fork bottom thread.

### Tightening torque:

Triple clamp bolt 15-18 Nm.

### Grease:

Öhlins front fork grease 00146-01 (red grease).

## Inspection and maintenance

Clean the front fork externally with a soft detergent. Use compressed air. Be careful that all dirt and debris is removed.

Keep the front fork clean and always spray it with oil (QS 14, WD40 or CRC 5-56 or similar) after washing the vehicle.

### CAUTION!

*Never use detergents that can damage the surfaces of the front fork. Use of thinner and brake cleaner will dry the surfaces too much..*

### NOTE!

*Make certain that your front fork is always filled with Öhlins High Performance Front Fork Oil (1309-01).*

### Inspection points (see opposite page):

1. Check the front fork for leakage.
2. Check the front fork tubes for external damages.
3. Fastening of caliper bracket and fender bracket.
4. Fastening to the vehicle.

Preventive maintenance and regular inspection reduces the risk of functional disturbance. If there is any need for additional service, please get in touch with an authorised Öhlins service workshop. There they have the necessary tools and know-how for whatever you need.

### NOTE!

*Regular maintenance and inspection contribute to the prevention of functional disturbances.*

### Recommended inspection and maintenance intervals:

Normal use	Once a year or every 5000 km
Race track	Every ten hours

### Once every 2nd year (or 20 000 km), general:

Change front fork oil, use Öhlins front fork oil (1309-01) only.

### NOTE!

*Discarded Öhlins products should be handled over to an authorized work shop or distributor for proper disposal.*

## Inspection points

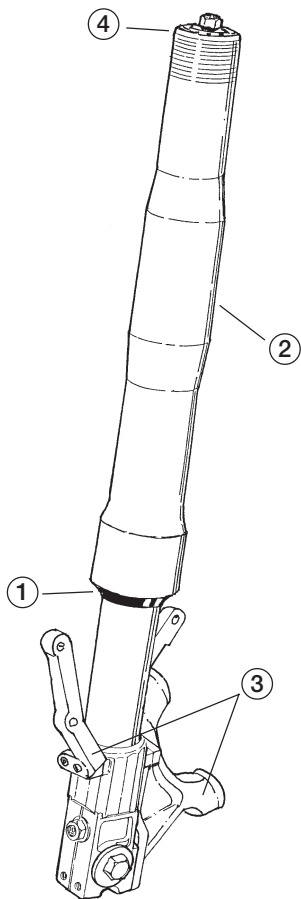

## Service tools

### *4701-01 Tool Kit*

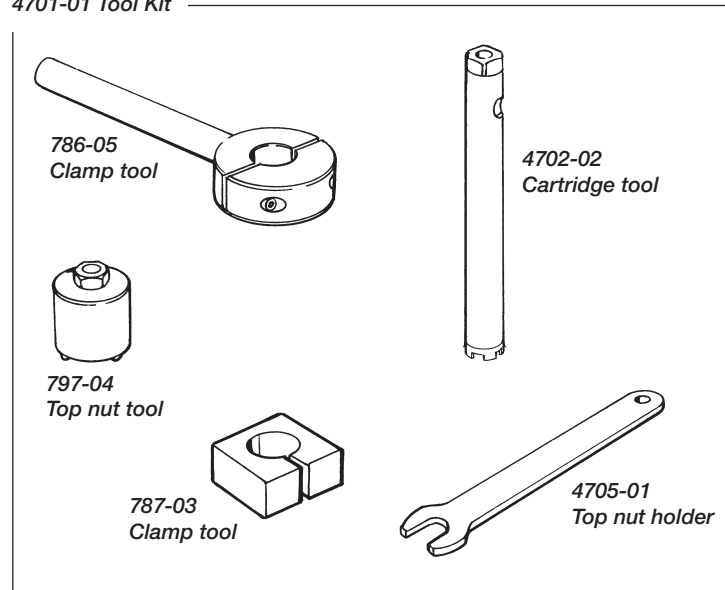

# More info

[www.ohlins.com](http://www.ohlins.com)

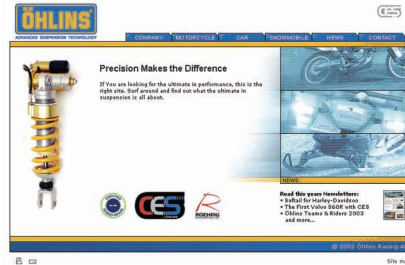

The ultimate suspension site.  
Find out everything about your suspension.  
Download mounting instructions, manuals and brochures.  
And a lot more.



Öhlins Racing AB, Box 722, S-194 27 Upplands Väsby, Sweden  
Phone +46 8 590 025 00, Fax +46 8 590 025 80

Your Öhlins dealer: